

Changed Date	Changed By	Approved By	Description	Revision

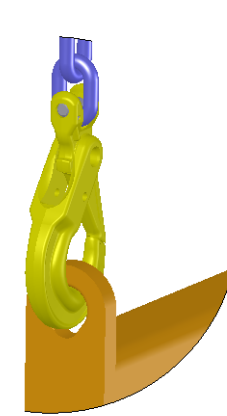

DETAIL B
SCALE 1 : 5

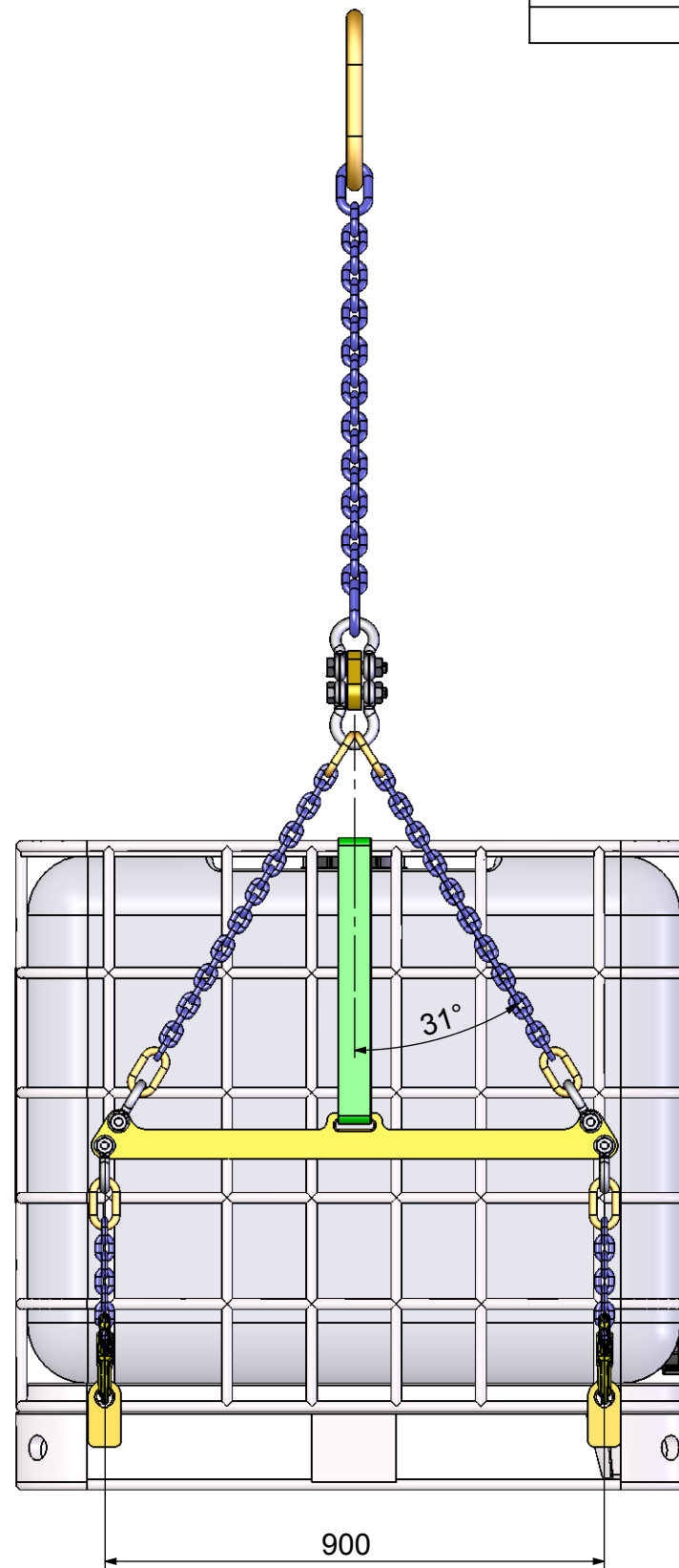
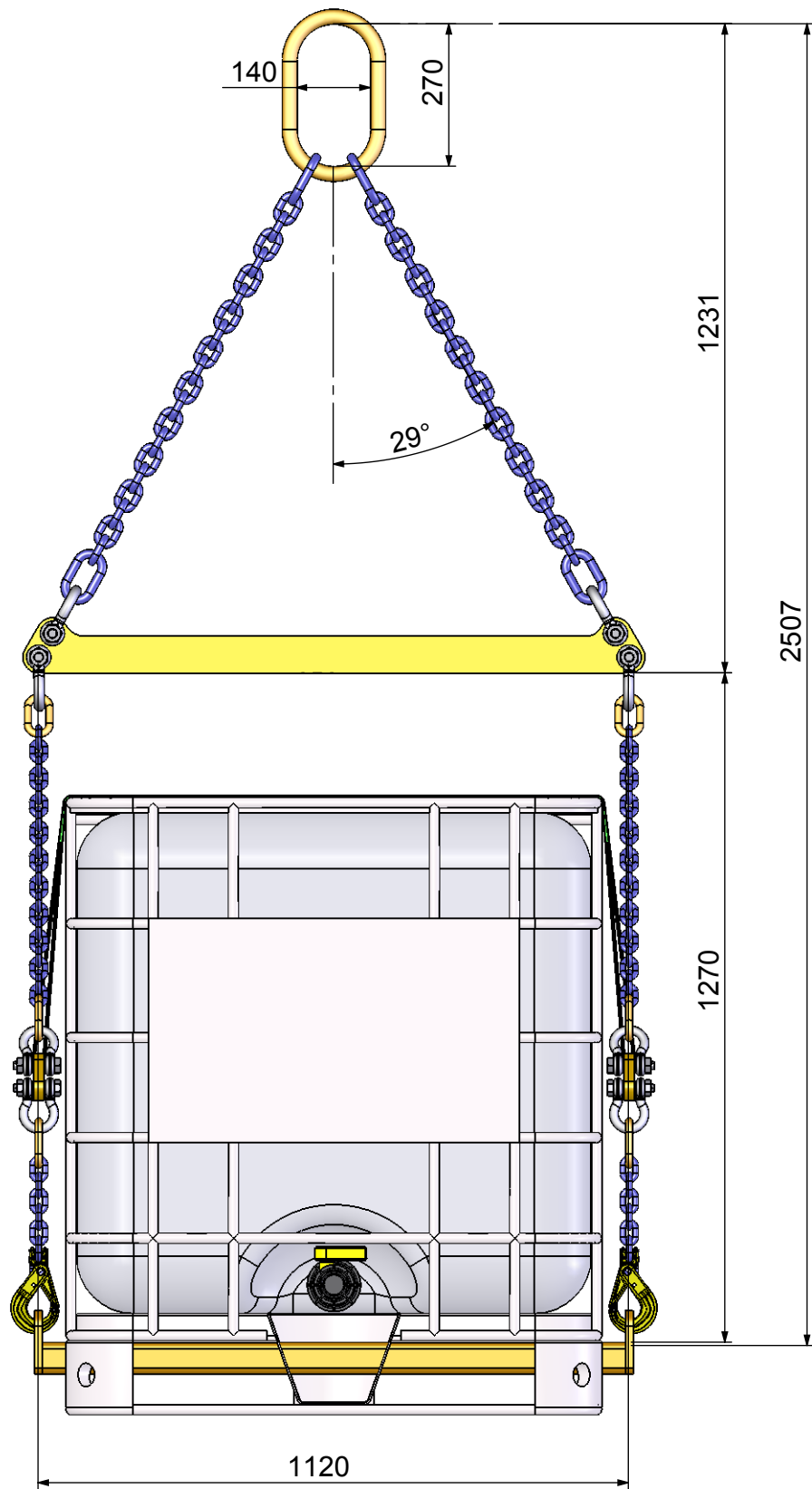
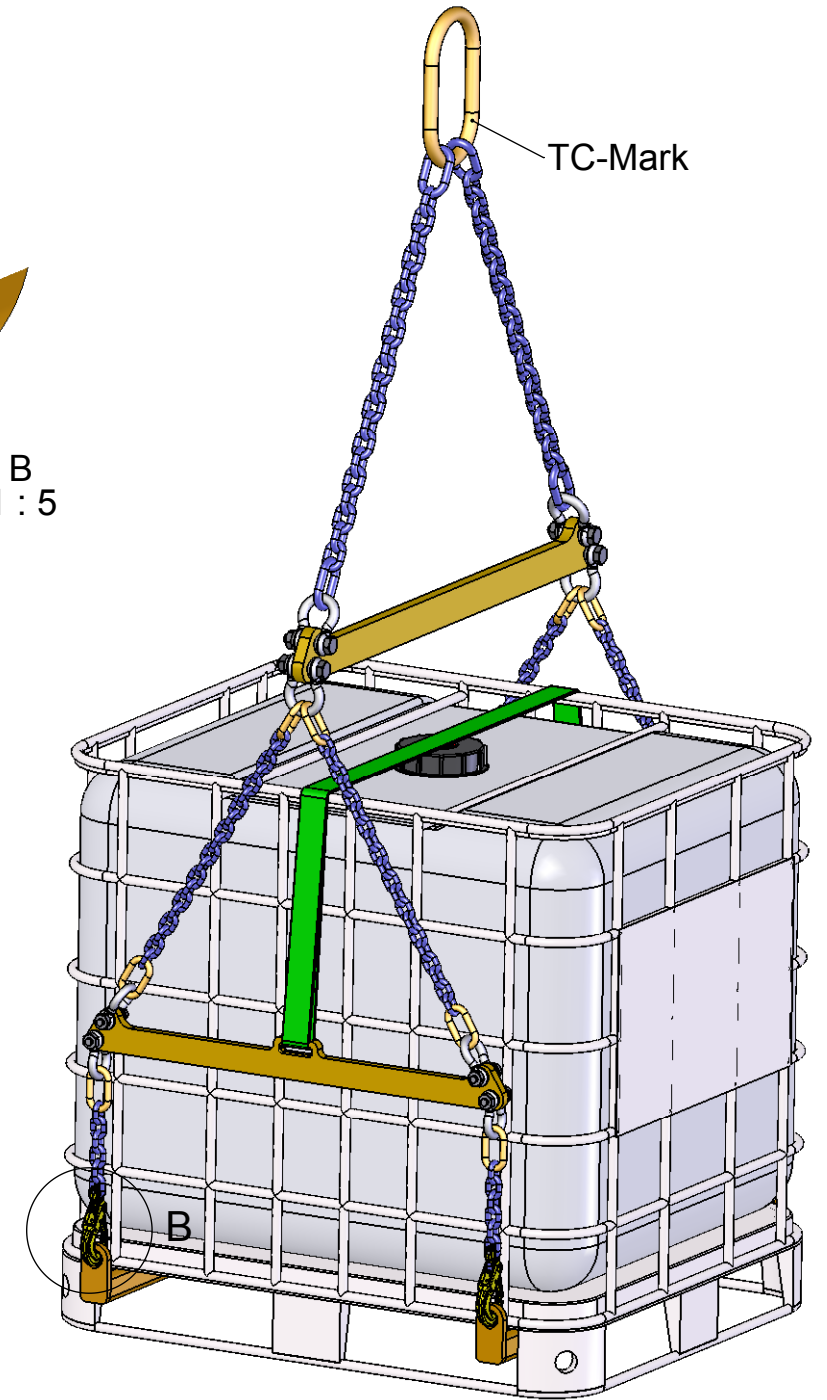

Notes:	
1 Standard	Designed acc. To Norsok R002 Annex F
2 Certificate.	Lifting Cert. / Decl. Of Conformity (F4) Material inspection certificate acc. to NS 10204,3.1
3 Marking on Product:	FRAM CE Item No T63445933 SN xxxx WLL 2 Ton
4 Proof Force:	39.2 kN
5 Weight:	88 Kg

This drawing shall not be reproduced, or in any way utilized for the manufacture of the component, without written consent. Any infringement will be legally pursued.

Date:	Design / Drawing:	Tracet:	Scale:
20.04.2023	GB		
Revision:	Heat Treatment:	Approved:	
02		SI	
Reference:			
Calculations:			

FRAM

Lifting Yoke for IBC Cont.
WLL 2 Ton
Item No: T63445933

Replacment for:	Replaced by:
Drawing nr:	634-45933
Size:	A3
Page	Page 1 of 1